



User Guide

GL10-3200END Digital Input Module



19011106A01

1

1. Overview

Thank you for purchasing the GL10-3200END digital input expansion module developed and manufactured independently by Inovance.

This product is a 32-channel digital transistor (SOURCE and SINK) input module used together with the AM600 series medium-sized PLC and the H3U series PLC main modules.

This guide describes the specifications, characteristics and using methods of the product. Read this guide carefully before using to ensure more safe usage. See the Medium-Sized PLC Programming Manual to understand the use of the user program development environment and design method of the user program of the product. You can download the latest materials from [www.inovance.com](http://www.inovance.com).

2. Safety Information and Precautions

Safety information and precautions are identified into two grades: Warning and Caution. Please make sure to operate properly with adequate safety assurance.

**WARNING** Indicates the improper operation which, if not avoided, may cause death or serious injury;

**CAUTION** Indicates the improper operation which, if not avoided, may cause moderate or minor injury, as well as equipment damage.

In some cases, even failure to follow "Cautions" may also lead to serious consequences. Please make sure to follow both warnings and cautions, otherwise, it may cause death or serious injury, as well as product and relevant equipment and system damage.

Please keep this guide well so that it can be read when necessary and forward this guide to the end user.

During control system design

- WARNING** Provide a safety circuit outside the PLC so that the control system can still work safely once external power failure or PLC fault occurs.
- Add a fuse or circuit breaker because the module may smoke or catch fire due to long-time overcurrent caused by operation above rated current or load short-circuit.

2

**CAUTION**

- An emergency stop circuit, a protection circuit, a forward/reverse operation interlocked circuit, and a upper position limit and lower position limit interlocked circuit must be set in the external circuits of PLC to prevent damage to the machine.
- To ensure safe operation, for the output signals that may cause critical accidents, please design external protection circuit and safety mechanism;
- Once PLC CPU detects abnormality in the system, all outputs may be closed; however, when a fault occurs in the controller circuit, the output may not be under control. Therefore, it is necessary to design an appropriate external control circuit to ensure normal operation;
- If the PLC's output units such as relays or transistors are damaged, the output may fail to switch between ON and OFF states according to the commands;
- The PLC is designed to be used in indoor electrical environment (overvoltage category II). The power supply must have a system-level lightning protection device, assuring that overvoltage due to lightning shock can't be applied to the PLC's power supply input terminals, signal input terminals and output terminals and so forth, so as to avoid damage to the equipment.

During installation

**WARNING**

- Installation must be carried out by the specialists who have received the necessary electrical training and understood enough electrical knowledge.
- Disconnect all external power supplies of the system before module assembly/disassembly and wiring. Failure to do so may result in electric shock, module fault or malfunction. Failure to do so may result in electric shock, module fault or malfunction.
- Do not use the PLC where there are dust, oil smoke, conductive dust, corrosive or combustible gases, or exposed to high temperature, condensation, wind & rain, or subject to vibration and impact. Electric shock, fire and malfunction may also result in damage or deterioration to the product.
- The PLC is open-type equipment that must be installed in a control cabinet with lock (cabinet housing protection >IP20). Only the personnel who have received the necessary electrical training and understood enough electrical knowledge can open the cabinet.

**CAUTION**

- Prevent metal filings and wire ends from dropping into ventilation holes of the PLC during installation. Failure to comply may result in fire, fault and malfunction.
- Ensure there are no foreign matters on ventilation surface. Failure to comply may result in poor ventilation, which may cause fire, fault and malfunction.
- Ensure the module is connected to the respective connector securely and hook the module firmly. Improper installation may result in malfunction, fault or fall-off.

During wiring

**WARNING**

- Wiring must be carried out by personnel who have received the necessary electrical training and understood enough electrical knowledge.
- Disconnect all external power supplies of the system before wiring. Failure to comply may result in electric shock, module fault or malfunction.
- Install the terminal cover attached to the product before power-on or operation after wiring is completed. Failure to comply may result in electric shock.
- Perform good insulation on terminals so that insulation distance between cables will not reduce after cables are connected to terminals. Failure to comply may result in electric shock or damage to the equipment.

**CAUTION**

- Prevent dropping metal filings and wire ends drop into ventilation holes of the PLC at wiring. Failure to comply may result in fire, fault and malfunction.
- The external wiring specification and installation method must comply with local regulations. For details, see the wiring section in this guide.
- To ensure safety of equipment and operator, use cables with sufficient diameter and connect the cables to ground reliably.
- Wire the module correctly after making clear of the connector type. Failure to comply may result in module and external equipment fault.
- Tighten bolts on the terminal block in the specified torque range. If the terminal is not tight, short-circuit, fire or malfunction may be caused. If the terminal is too tight, fall-off, short-circuit, fire or malfunction may be caused.
- If the connector is used to connect with external equipment, perform correct crimping or welding with the tool specified by manufacturer. If connection is in poor contact, short-circuit, fire or malfunction may be caused.
- A label on the top of the module is to prevent foreign matters entering the module. Do not remove the label during wiring. Remember to remove it before system operation, facilitating ventilation.
- Do not bundle control wires, communication wires and power cables together. They must be run with distance of more than 100 mm. Otherwise, noise may result in malfunction.
- Select shielded cable for high-frequency signal input/output in applications with serious interference so as to enhance system anti-interference ability.

3

During maintenance & inspection

**WARNING**

- Maintenance & inspection must be carried out by personnel who have the necessary electrical training and experience.
- Do not touch the terminals while the power is on. Failure to comply may result in electric shock or malfunction.
- Disconnect all external power supplies of the system before cleaning the module or re-tightening screws on the terminal block or screws of the connector. Failure to comply may result in electric shock.
- Disconnect all external power supplies of the system before removing the module or connecting/removing the communication wirings. Failure to comply may result in electric shock or malfunction.

**CAUTION**

- Get acquainted with the guide and ensure safety before online modification, forcible output, and RUN/STOP operation.
- Disconnect the power supply before installing/removing the extension card.

At disposal

**CAUTION**

- Treat scrapped module as industrial waste. Dispose the battery according to local laws and regulations.

3. Product Information

Model and Nameplate

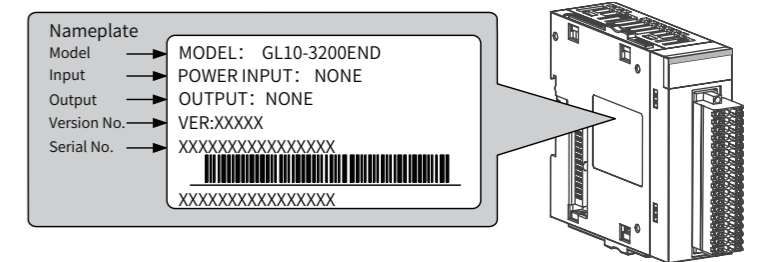
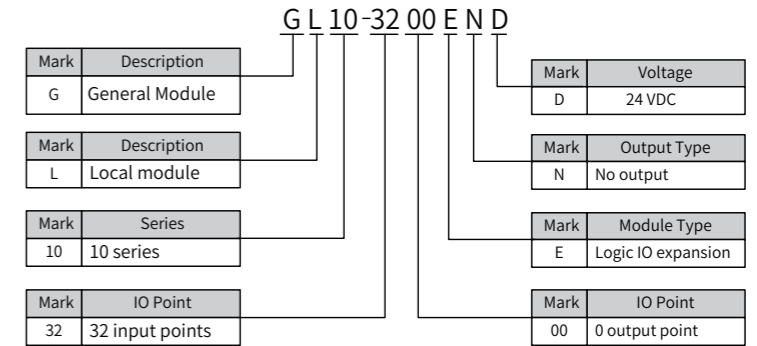

Figure 1 Description of model and nameplate

Model	Classification	Description	Applicable to
GL10-3200END	Digital input module	32-point DI module; 24 VDC input	AM600 series, H3U series

External Interface

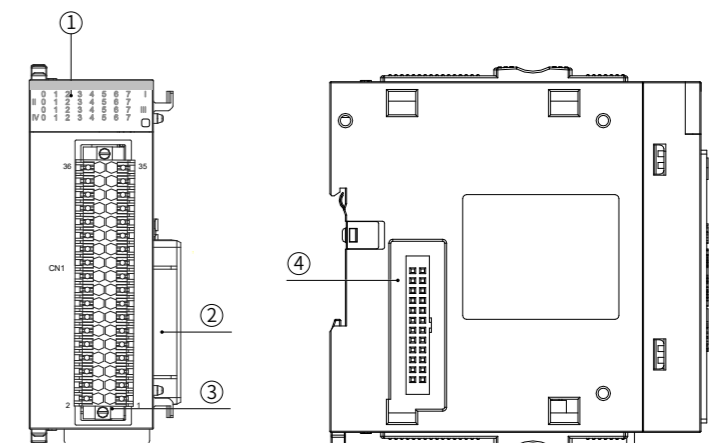

Figure 2 Diagram of digital input module interface

No.	Interface Name	Function
1	Signal indicators	Corresponding to various input signals ON: input active OFF: input inactive
2	Local expansion module back-end interface	Connect back-end module, not supporting hot plugging
3	User input terminal	16-channel inputs x 2
4	Local expansion module front-end interface	Connect front-end module, not supporting hot plugging

General Specifications

Item	Specifications
Input channel	32
Input connecting mode	40-pin high-density terminal
Input type	Digital input
Input mode	SINK/SOURCE
Input voltage class	24 VDC (max.: 30 V)
Internal 5 V power consumption	65 mA(typical)
Input current (typical)	4 mA
ON voltage	19 VDC
OFF voltage	< 5 VDC
Interface hardware filter time constant	10 ms
Input resistance	5.6 K
Input signal form	DC voltage input, supporting SINK/SOURCE input
Isolation method	Opto-couplers isolation
Input action display	Input indicator ON when the input is in the driving state

Power De-rating Diagram

The number of channels used must be derated in different temperature environments (especially in the high temperature environment) to ensure module application reliability and safety.

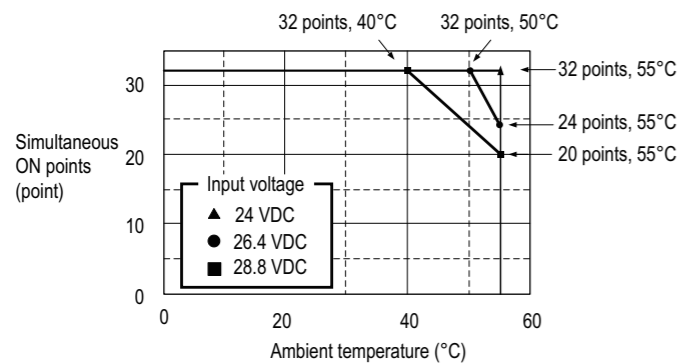

4. Mechanical Design Reference

Mounting Dimensions

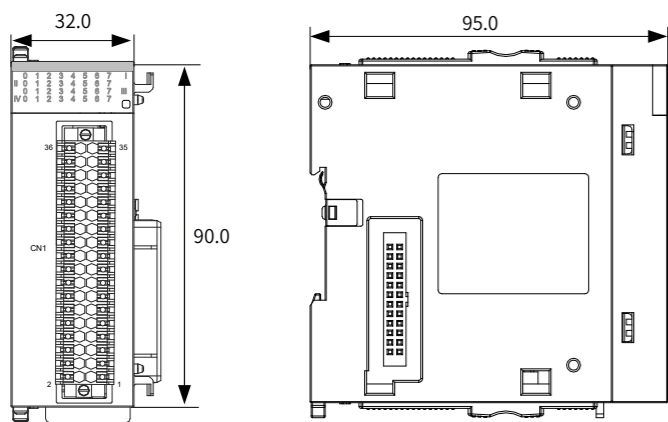

Figure 3 Mounting dimensions (in mm)

5. Electrical Design Reference

Cable Preparation Procedures

- 1) Strip back the wire outer coating by 6 mm. Pass the cable through the tube of proper wire size.
- 2) Insert the exposed end into the hole of the cable lug, and then crimp it with recommended crimping tool.
- 3) Put the cable lug onto the terminal and tighten the screw with a screwdriver. The maximum tightening torque is 0.45 N.m.

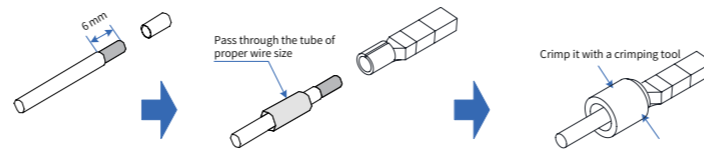

Figure 4 Diagram of cable preparing

Terminal Signal Arrangement

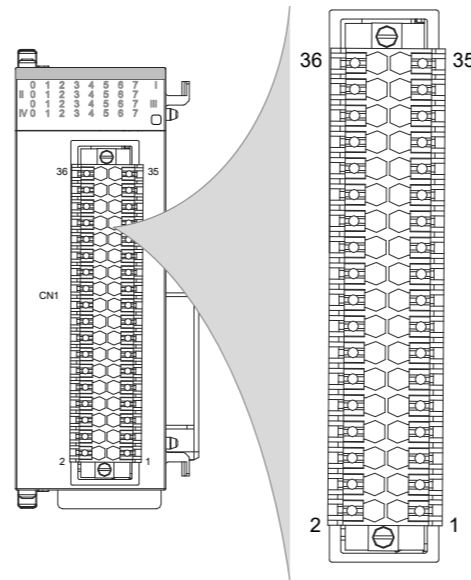

Figure 5 Terminal definition of the GL10-3200END digital input module

The following figure shows the internal circuit and external wiring of the interface. Please finish corresponding wiring according to actual requirements:

- ◆ Column B is Sink type which uses 24VDC Power Supply; Column A is Source type which uses 24VDC-1 Power Supply as shown below:

External Wiring	Signal Name	Terminal No.	Signal Name	External Wiring
	B (Sink)		A (Source)	
24VDC +	SS2 Common (SS2)	36	SS3 Common (SS3)	24 VDC-1 +
SW	Input (X27)	34	Input (X37)	SW
SW	Input (X26)	32	Input (X36)	SW
SW	Input (X25)	30	Input (X35)	SW
SW	Input (X24)	28	Input (X34)	SW
SW	Input (X23)	26	Input (X33)	SW
SW	Input (X22)	24	Input (X32)	SW
SW	Input (X21)	22	Input (X31)	SW
SW	Input (X20)	20	Input (X30)	SW
24VDC +	SS0 Common SS0	18	SS1 Common SS1	24VDC-1 +
SW	Input (X07)	16	Input (X17)	SW
SW	Input (X06)	14	Input (X16)	SW
SW	Input (X05)	12	Input (X15)	SW
SW	Input (X04)	10	Input (X14)	SW
SW	Input (X03)	8	Input (X13)	SW
SW	Input (Y02)	6	Input (X12)	SW
SW	Input (X01)	4	Input (X11)	SW
SW	Input (X00)	2	Input (X10)	SW

Wiring Precautions

- 1) After the I/O terminal block is installed to the CN5, fix it at 0.2 to 0.25 Nm torque, as shown in the figure below:

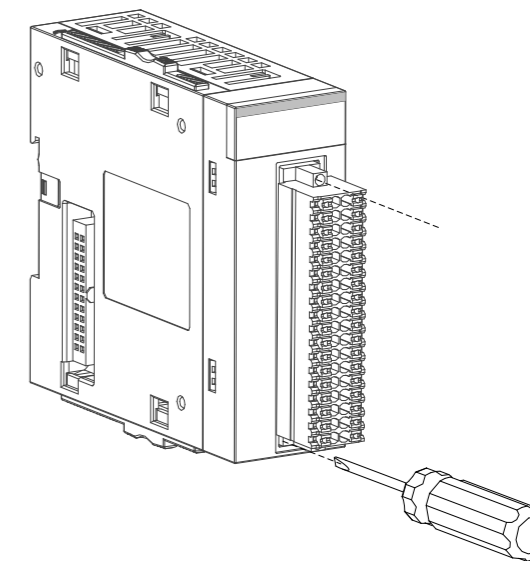

- 2) Do not bundle the terminal connection cables together with power cables (high voltage, large current) which produce strong interference signals. Separate it from other cables and avoid cabling in parallel.

INOVANCE Warranty Agreement

- 1) Inovance provides an 18-month free warranty to the equipment itself from the date of manufacturing for the failure or damage under normal use conditions.
- 2) Within the warranty period, maintenance will be charged for the damage caused by the following reasons:
  - a. Improper use or repair/modification without prior permission
  - b. Fire, flood, abnormal voltage, natural disasters and secondary disasters
  - c. Hardware damage caused by dropping or transportation after procurement
  - d. Operations not following the user instructions
  - e. Damage out of the equipment (for example, external device factors)
- 3) The maintenance fee is charged according to the latest Maintenance Price List of Inovance.
- 4) If there is any problem during the service, contact Inovance's agent or Inovance directly.
- 5) Inovance reserves the rights for explanation of this agreement.

Suzhou Inovance Technology Co., Ltd.  
 Address: No.16, Youxiang Road, Yuexi Town, Wuzhong District, Suzhou 215104, P.R. China  
 Website: <http://www.inovance.com>